

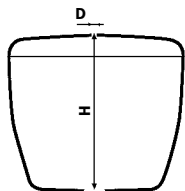

I - PREPARING THE MECHANISM



Measure the cistern

- H (from the top of the lid to the inside base of the cistern)
- D (diameter of the hole in the lid)

▲ Check the position of the stirrup

If the stirrup (m) is correctly positioned on the basis of the below table, proceed to step 6. Otherwise, carry out all of the following steps:

- 1 Unclip the lift rod (c)
- 2 Remove the stirrup (m), by pressing on the two catch clips (k)
- 3 Cut the overflow (l) if necessary according to the table
- 4 Reposition the stirrup in its seat and slide it to the required position (desired setting notch number visible)
- 5 Clip lift rod (c) back into the hole of the overflow (l) which has the same number as that of the setting notch
- 6 Unscrew the strainer nut (f)

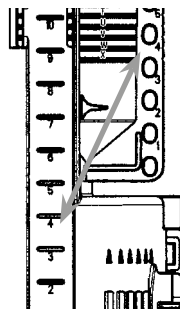
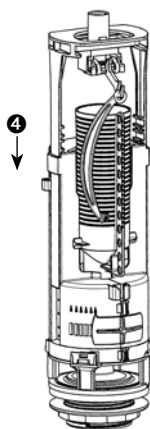
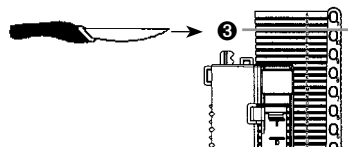
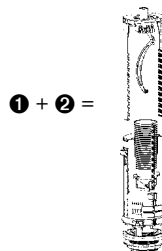
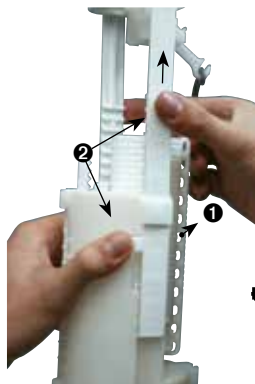

Visible stirrup notch
no. 4 = position of lift rod no. 4

		Height H of cistern	
		Diameter D of hole in lid 18 to 38 mm and 45 to 50 mm	Diameter D of hole in lid 38 to 44 mm
No. of notch visible on lift rod	11	430 to 417	448 to 435
	10	416 to 405	434 to 423
	9	404 to 393	422 to 411
	8	392 to 381	410 to 399
	7	380 to 369	398 to 387
	6	368 to 357	386 to 375
	5	356 to 345	374 to 363
	4	344 to 333	362 to 351
	3	332 to 321	350 to 339
	2	320 to 309	338 to 327
	1	308 to 297	326 to 315
	Mini	296 to 282	314 to 300

Stirrup notch	Cut on overflow tube
3	C mark visible
2	F mark visible
1	I mark visible
Mini	L mark visible

II - INSTALLATION

Position the mechanism in the cistern and secure it in place with the nut (f)

Manually screw the flush valve nut (f) until it is in contact with the ceramic. If necessary give an extra quarter turn (maximum) with the appropriate spanner.

NB : Excessive tightening can damage the mechanism and would not be covered by the guarantee.

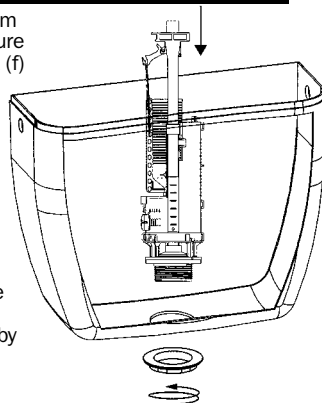

III - ASSEMBLING BOWL AND CISTERN

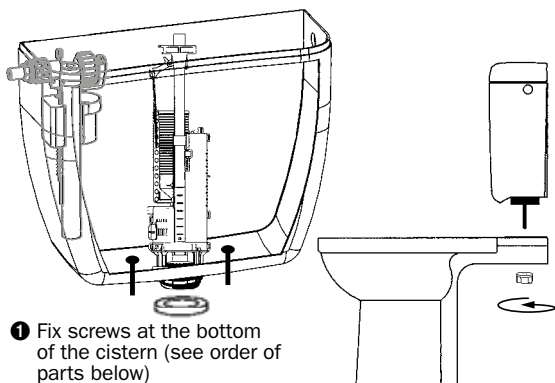

1 Fix screws at the bottom of the cistern (see order of parts below)

2 Position the latex foam gasket on the nut (f)

3 Position the cistern on the bowl and secure it with wing nuts

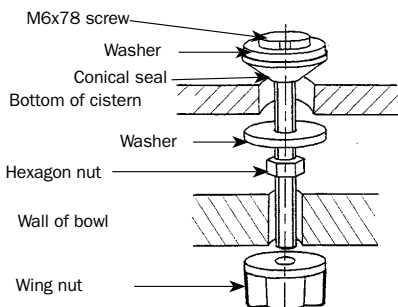

V - INSTALLATION OF BUTTON

1 Once the set-up has been completed, put on the lid on the cistern

2 If the hole in the lid (D) is > 38 mm and < 45 mm, remove the escutcheon (b)

3 Position the button on the lid and screw until tight.

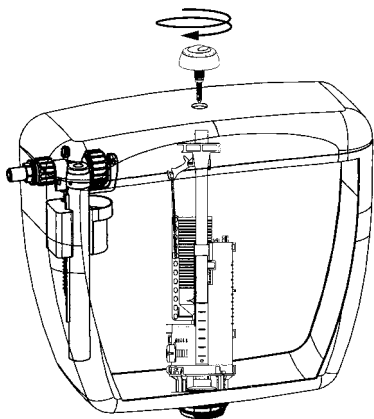

IV - SETTING WATER LEVEL

After having connected your ballcock to the water supply, open the tap and set the level of the long flush using the ballcock (see overleaf).

Note: The max. water level should be 20 mm lower than the overflow tube (l).

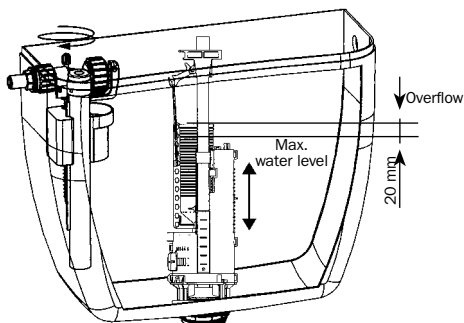

To adjust the water level of the short flush, slide the cursor along (j). Immerse the cursor of 40 mm.

Note : The closer the cursor is to 18, the more water will be flushed.



In some (rare) cases, the residual water level (amount of water remaining after the long flush) must be increased to ensure more efficient cleaning. To do this, move the sliding valve (d) to the left (the more it is open, the more the residual water increases).

Note: Increasing the residual water reduces the volume of water flushed. If necessary, readjust the max. water level using the ballcock.

VI - MAINTENANCE

Changing the valve gasket

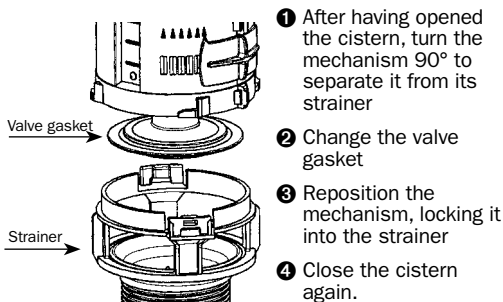

1 After having opened the cistern, turn the mechanism 90° to separate it from its strainer

2 Change the valve gasket

3 Reposition the mechanism, locking it into the strainer

4 Close the cistern again.